

Big Smoky & STC-50 Heat & Smoke Vent McCabe Link Reset Instructions

Tools Needed: ½" Wrench – ½" Ratcheting Wrench is preferred

Note: Once the McCabe link has been tripped via a supplied voltage, you will first need to reset the McCabe link and mechanism before proceeding to closing the unit. Please refer to our closing instructions after the McCabe link mechanism is reset.

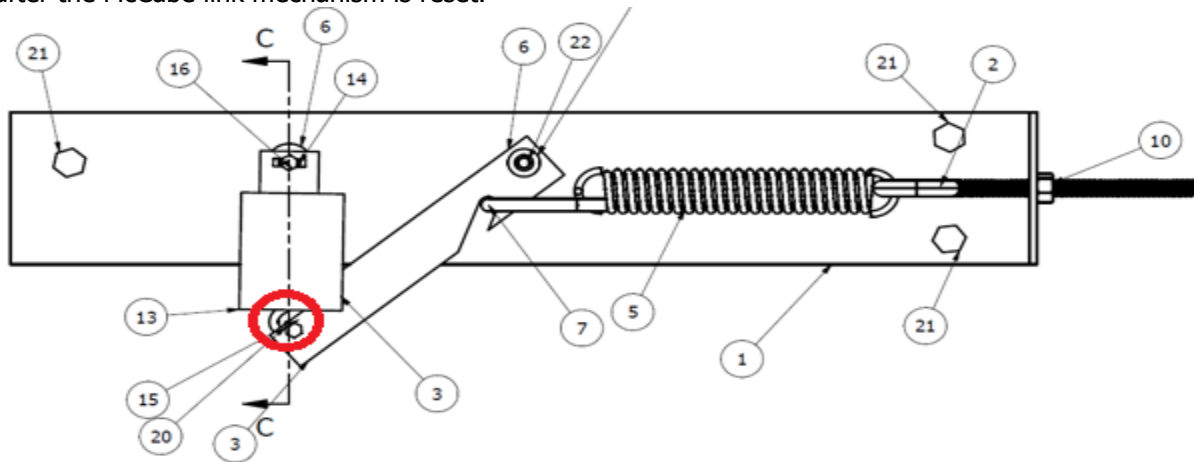

Figure 1: McCabe Link Mechanism

Important: Mark the location of the eye bolt nut (10) on the eye bolt threads (2).

1. Loosen the eye bolt nut (10) using your ½" wrench to take all the tension off the spring (5) and the cable connected to the S-hook (7).
2. Reset the McCabe link by reattaching the smaller McCabe link S-hook, circled in red, back into the McCabe link's securing pin as shown in Figure 2 below. The other end of the small S-Hook will remain bolted to the bottom of the slotted mechanism arm (3).



Figure 2: McCabe Link S-Hook Reset Detail

3. Connect the large S-hook (7) into the notch of the slotted mechanism arm (3) as shown in Figure 1 above.
4. Using your ½" wrench, retighten the eye bolt nut (10) till the eye bolt is back to its original location marked earlier and tension is put back onto the spring (5).
5. Refer to our closing instructions to close the covers on your unit