

ACCESS DOOR

Cam and Hinge Access Doors

For Flat High Pressure Single Wall Ductwork

DCM HP
DHG HP

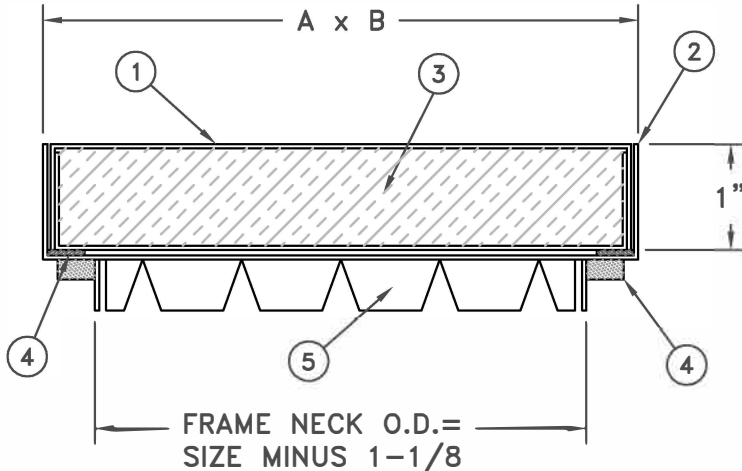

SPECIFICATIONS:

1. Formed 24 gauge metal door
2. Formed 22 gauge metal frame
3. Fiberglass insulation
4. Closed cell neoprene gasket
5. Preformed dovetail tabs

NOTES:

1. Available in galvanized steel. Contact factory for availability of other materials.
2. Available for single wall duct applications.
3. Insulation R-value of 3 (estimate).
4. Tested to 10" S.P. with minimal leakage.
5. Reference chart for sizes.

STANDARD SIZES

SIZE	WIDTH A	HEIGHT B	FRAME NECK O.D.	CAMS DCM	CAMS DHG
6x6	6	6	4-7/8 x 4-7/8	4	3
8x8	8	8	6-7/8 x 6-7/8	4	3
10x10	10	10	8-7/8 x 8-7/8	4	3
12x12	12	12	10-7/8 x 10-7/8	4	3
14x14	14	14	12-7/8 x 12-7/8	4	3
16x16	16	16	14-7/8 x 14-7/8	8	6
18x18	18	18	16-7/8 x 16-7/8	8	6
20x20	20	20	18-7/8 x 18-7/8	8	6
24x24	24	24	22-7/8 x 22-7/8	8	6

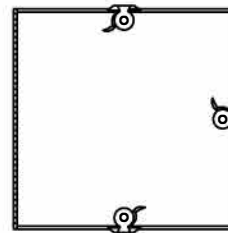

MODEL DHG HP
HINGE AND CAM

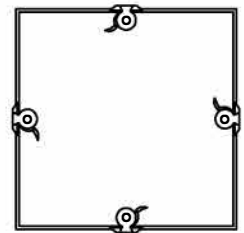

MODEL DCM HP
DUAL CAMS

JOB NAME: _____
 LOCATION: _____
 ARCHITECT: _____
 ENGINEER: _____
 CONTRACTOR: _____

SUBMITTED BY: _____