

STANDARD PART #'S		
DOOR SIZE	PART #	LATCH QTY.
12" X 12"	3207014	1
12" X 24"	3207019	2
18" X 18"	3207024	2
24" X 24"	3207030	2
24" X 36"	3207034	3
36" X 36"	3207046	5
36" X 42"	3207048	5

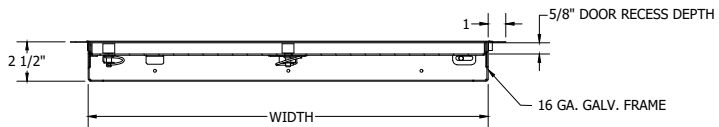
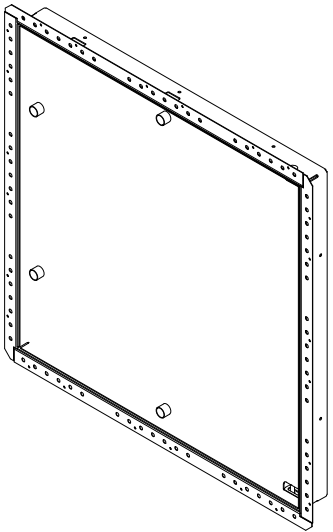

SECTION A-A

FINISH: WHITE POWDER COAT

ORDER WILL NOT BE RELEASED FOR FABRICATION UNTIL SIGNED COPY IS RECEIVED

VERIFICATION AND APPROVAL OF GENERAL ARRANGEMENT AND OVERALL DIMENSIONS OF THIS DOCUMENT ARE REQUIRED BEFORE THE ORDER IS ENTERED FOR MANUFACTURING

APPROVAL SIGNATURE \_\_\_\_\_

TITLE \_\_\_\_\_

DATE \_\_\_\_\_

DRAWN CD	02/09/2023	Duravent Group Fax: 855-549-2674 www.duraventgroup.com 28 W. Adams, Suite 1810 Detroit, MI 48226 Ph: 800-624-8642	
CHECKED	<b>MILCOR</b> - duravent	TITLE	
QA	TOLERANCE	DWR ACCESS DOOR SUBMITTAL	
MFG	UNLESS SPECIFIED	SIZE	DWG NO
APPROVED	.XXX ± 0.005"	C	SUBMITTAL
	.XX ± 0.01"	SCALE	REV
	FRACT. ± 1/16"		
	ANGLES ± 1'		
		SHEET 1 OF 1	